

MALE END VIEW

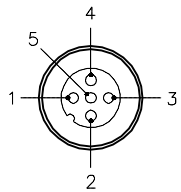

- 1 = BROWN
- 2 = WHITE
- 3 = BLUE
- 4 = BLACK
- 5 = BARE (SHIELD)

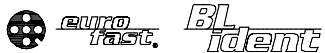

SPECIFICATIONS

CONTACT CARRIER MATERIAL	NYLON OR TPU
MOLDED HEAD MATERIAL/COLOR	TPU/BLACK
CONTACT MATERIAL/PLATING	BRASS/GOLD
COUPLING NUT MATERIAL/PLATING	BRASS/NICKEL
RATED CURRENT [A]	4.0 A
RATED VOLTAGE [V]	250 V
OUTER JACKET MATERIAL/COLOR	TPU/YELLOW
CONDUCTOR INSULATION MATERIAL	PVC
NUMBER OF CONDUCTORS [AWG]	2x22 AWG, 2x24 AWG, 24 AWG DRAIN
SHIELDING	ALUMINUM/POLYESTER FOIL & T-C BRAIDED
TEMPERATURE RANGE	-40°C to +90°C (-40°F to +194°F)
PROTECTION CLASS	NEMA 1,3,4,6P AND IEC IP68, IP69K

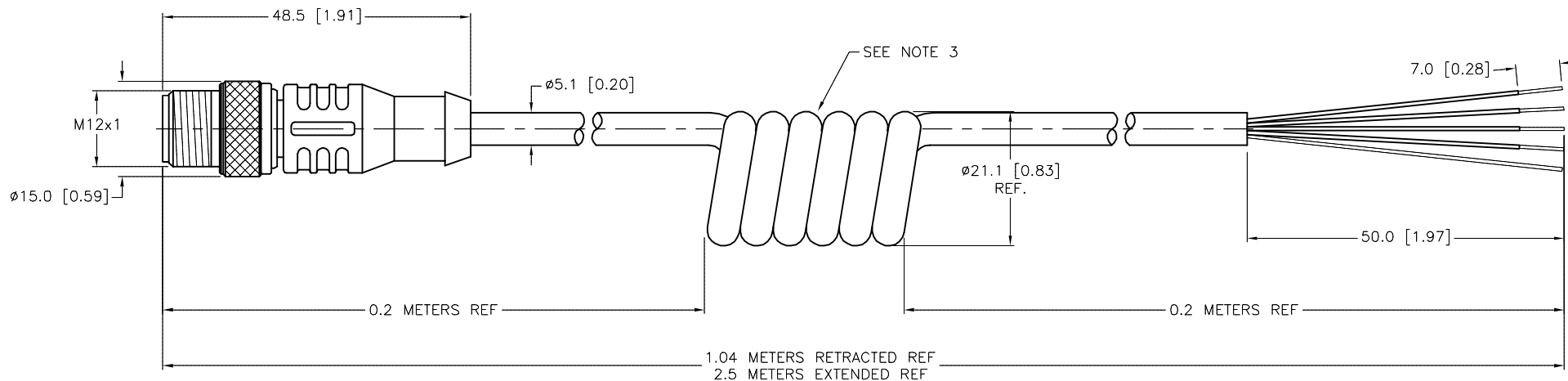

SOURCE DRAWING - FOR REFERENCE ONLY

NOTES:

1. "/S90" DESIGNATES THERMOPLASTIC POLYURETHANE (TPU) CABLE.
2. "/S2501" DESIGNATES RFID CABLE WITH TPU JACKET AND BLACK OVERMOLD. USE "C" SIZE (CM7) BODY FOR EUROFAST CONNECTOR.
3. NUMBER OF COILS IS REFERENCE ONLY.

RELATED DOCUMENTS 1. 2. 3. 4.	3RD ANGLE PROJECTION 	THIS DRAWING IS CONFIDENTIAL AND THE PROPERTY OF TURCK INC. USE OF THIS DOCUMENT WITHOUT WRITTEN PERMISSION IS PROHIBITED.		 3000 CAMPUS DRIVE MINNEAPOLIS, MN 55441 1-800-544-7769 (763) 553-7300 (763) 553-0708 fax www.turck.us	
	MATERIAL SEE SPECIFICATIONS	DRFT RWC APVD	DATE 02/16/09 SCALE 1=1.0	DESCRIPTION RS 4.5T-2.5/S2501/S90-SP	
FINISH SEE SPECIFICATIONS	ALL DIMENSIONS DISPLAYED ON THIS DRAWING ARE FOR REFERENCE ONLY	UNIT OF MEASUREMENT MILLIMETER [INCH]		IDENTIFICATION NO. U2-15276	REV F
F UPDATE CABLE DIAMETER PER ECO REV DESCRIPTION	KMY 01/25/13 BY DATE ECO NO.	CONTACT TURCK FOR MORE INFORMATION		DO NOT SCALE THIS DRAWING	FILE: U2-15276 SHEET 1 OF 1